

# Centrifugal Pumps



## HORIZONTAL SELF-PRIMING CENTRIFUGAL PUMPS

### TYPE RSM



EL-MOTOR DRIVEN PUMP

### DESIGN FEATURES

INTEGRAL PRIMING AND AIR SEPARATION  
NO EXTERNAL PRIMING SYSTEM TO BE USED  
NO VALVES OR EXTERNAL BYPASS PIPING FOR PRIMING  
ONE PIECE CASING  
BACK PULL-OUT CONSTRUCTION  
STANDARD MOTOR TO BE USED  
FROM - (B5) OR (B3/B5)

### APPLICATIONS

MARINE SERVICE  
INDUSTRIAL SERVICE  
AGRICULTURAL SERVICE  
GENERAL WATER SUPPLY

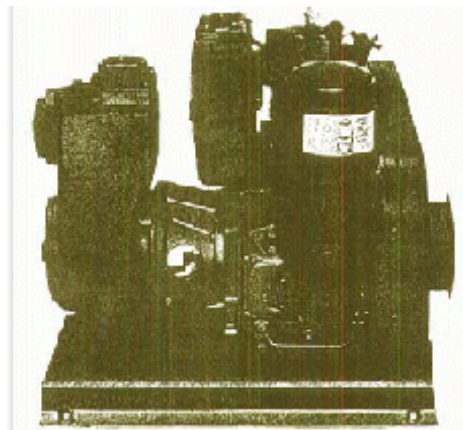

DIESEL OR GASOLINE DRIVEN PUMP

# SECTIONAL VIEW

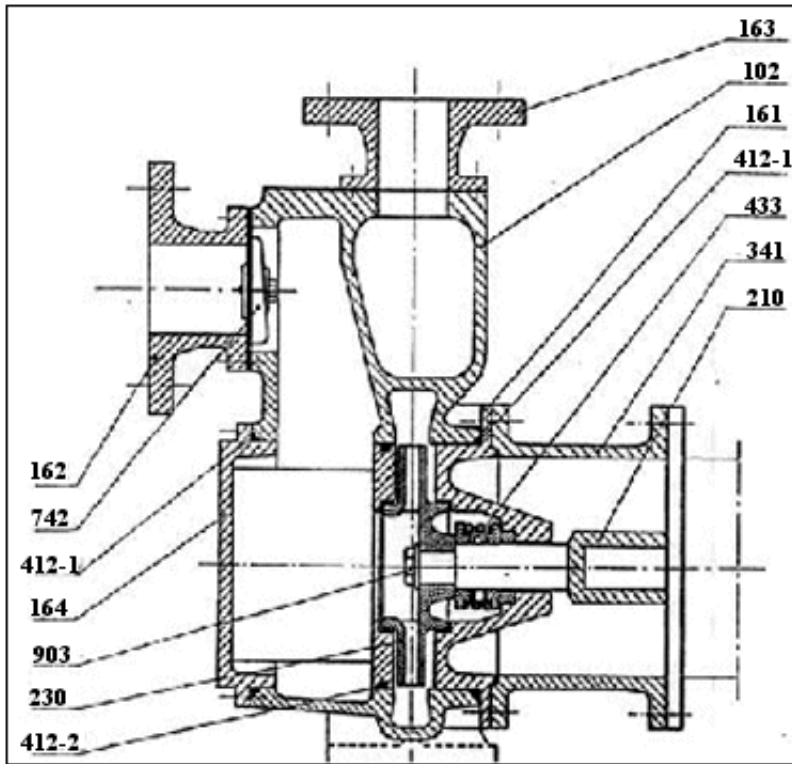

Pos no.	Description	Pcs.	Material
102	Volute casing	1	c.l./brz.
161	Casing cover	1	c.l./brz.
162	Suction cover	1	c.l./brz.
163	Discharge cover	1	c.l./brz.
164	Inspection cover	1	c.l./brz.
210	Pump shaft	1	st. stl.
230	Impeller	1	brz.
341	Motor support	1	c.l.
412-1	O-Ring	2	
412-2	O.Ring	1	
433	Mech. seal	1	
742	Check valve	1	Nitril rubber
903	Washer a.set screw-Imp	1	st. stl.

## TESTING

All pumps are hydraulic and capacity tested in our test department and works certificate will be issued.

-Upon request certificates from any classification society can be issued.

## TYPICAL STANDARD MATERIALS

Casing and cover in closed grained cast iron (GG 25) - Impeller (and wear rings) in bronze RM 10 (86 Cu - 10 Sn - 1,5 Pb -2,5 Zn) - and shaft in stainless steel (AISI 329).

Or all parts in bronze alloys according to specifications, and shaft in stainless steel (AISI 329).

Or all parts in steel or alloyed steel according to specifications - and shaft in stainless steel (AISI 329). OR OTHER MACHINEABLE ALLOYS

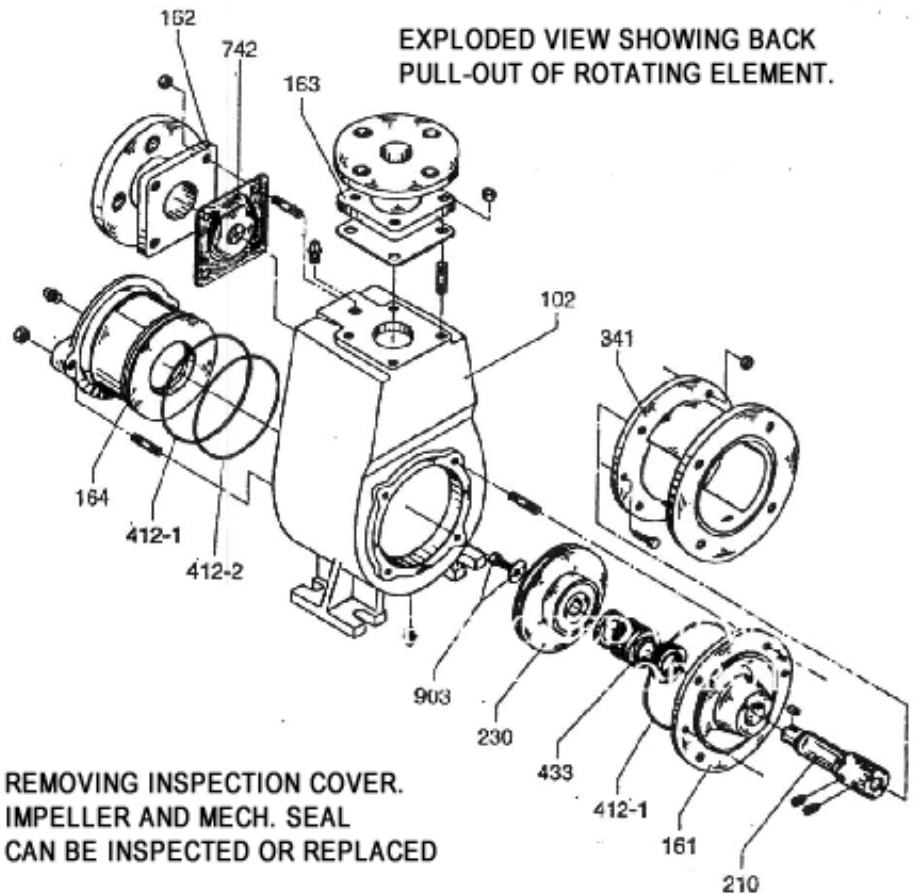

# INTEGRAL PRIMING AND AIR SEPARATION

Fig. No 1

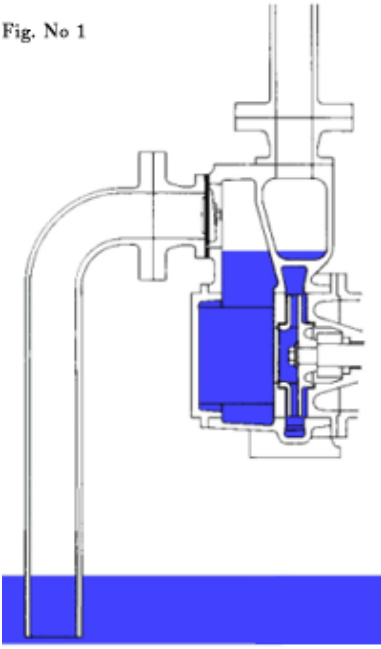

Double volute design exhausts suction with only an initial priming charge of liquid in the casing - (to be added before first starting only).  
- See fig. No. 1.

Fig. No 2

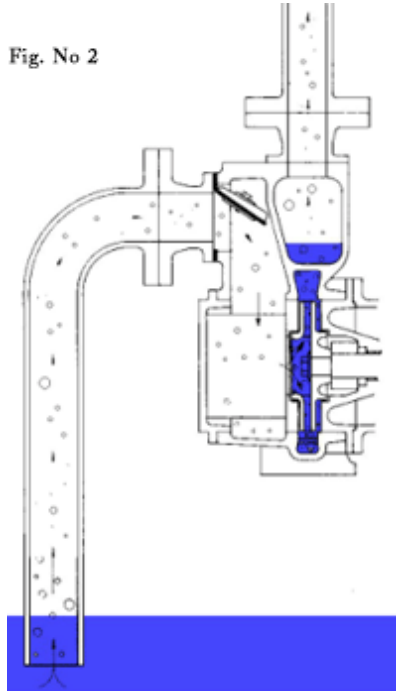

During priming cycle lower volute acts as intake while upper volute discharges liquid and entrained air into separation chamber. Air is separated and expelled through pump discharge while liquid recirculates into lower volute.  
- See fig. No. 2.

Fig. No. 3

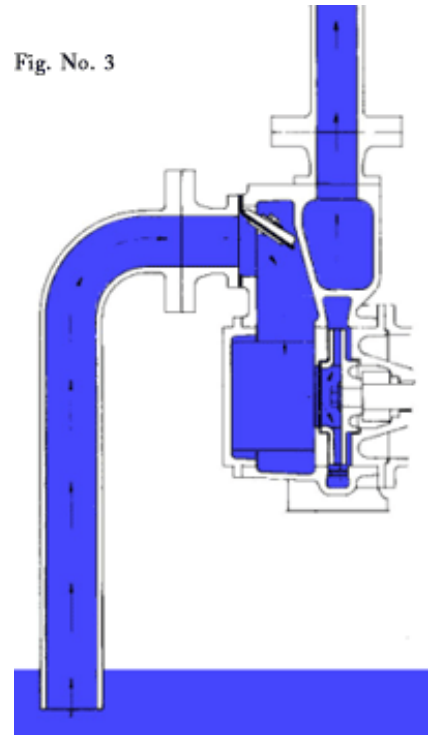

When air is completely exhausted from suction and impeller is filled with liquid - pump is primed and functions as a normal centrifugal pump with double volutes.  
- See fig. No. 3.

Casing is designed to contain a volume of liquid for repriming and no valve is required on suction or discharge side - on suction side a removable built-in swing type check valve fitted.

# Type RSM 32-25-100 - 100-80/250 with electric motor

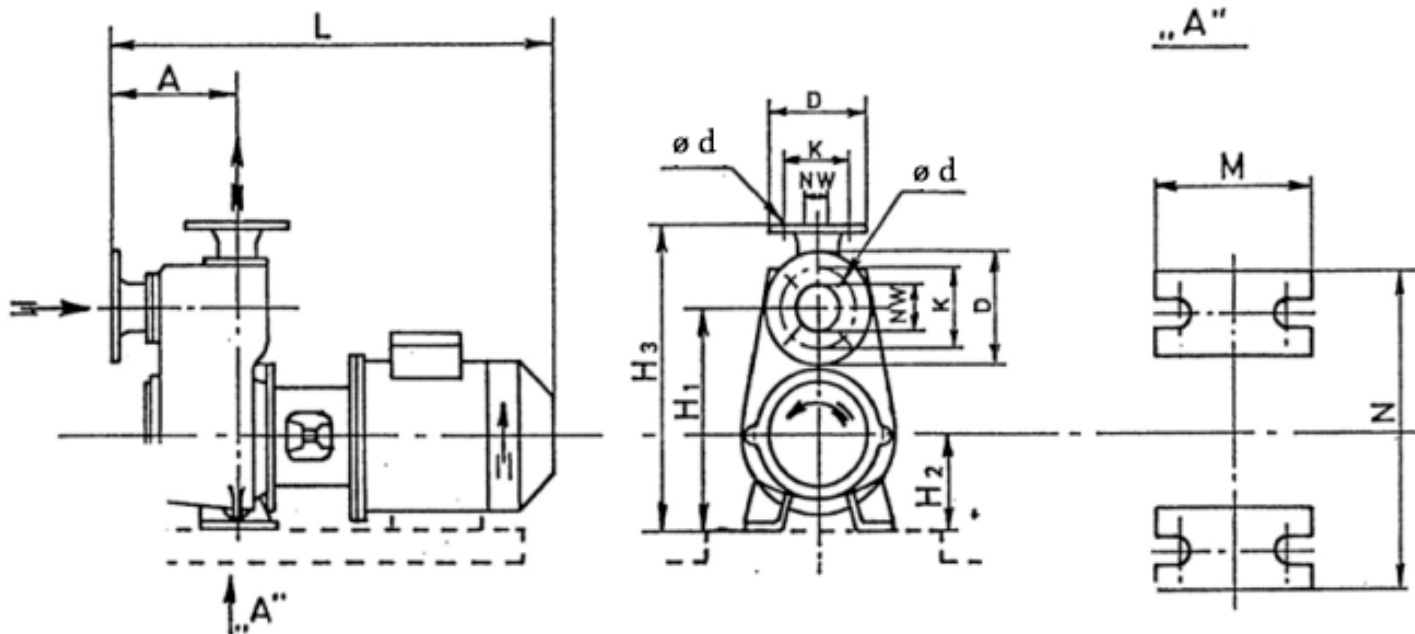

TYPE	SUC. FLANGE				DEL. FLANGE				A	L	H <sub>1</sub>	H <sub>2</sub>	H <sub>3</sub>	M	N	PUMP WEIGHT KG
	NW	K	D	d	NW	K	D	d								
32-25/100	32	100	140	4-18	25	85	115	4-14	145	545	240	90	340	100	180	23
40-32/100	40	110	150	4-18	32	100	140	4-18	145	545	240	90	340	100	180	25
50-40/125	50	125	165	4-18	40	110	150	4-18	160	563	280	112	405	100	210	35
65-50/125	65	145	185	4-18	50	125	165	4-18	160	630	280	112	405	100	210	37
80-65/125	80	160	200	8-18	65	145	185	4-18	210	762	327	132	475	125	240	63
100-80/125	100	180	220	8-18	80	160	200	8-18	210	762	327	132	475	125	240	65
65-50/160	65	145	185	4-18	50	125	165	4-18	200	757	370	160	505	125	265	60
80-65/160	80	160	200	8-18	65	145	185	4-18	200	940	370	160	505	125	265	68
80-65/200	80	160	200	8-18	65	145	185	4-18	210	835	420	180	570	160	345	85
100-80/200	100	180	220	8-18	80	160	200	8-18	210	835	420	180	570	160	345	90
80-65/250	80	160	200	8-18	65	145	185	4-18	210	760	465	200	615	160	400	100
100-80/250	100	180	220	8-18	80	160	200	8-18	210	760	465	200	615	160	400	105

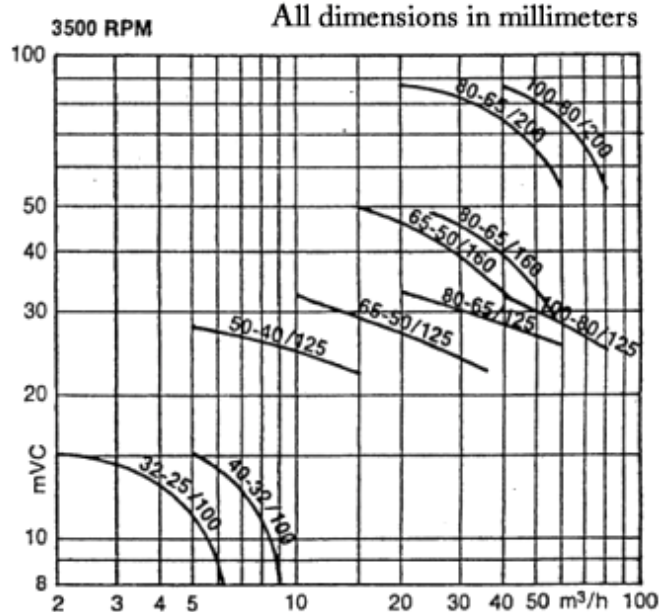
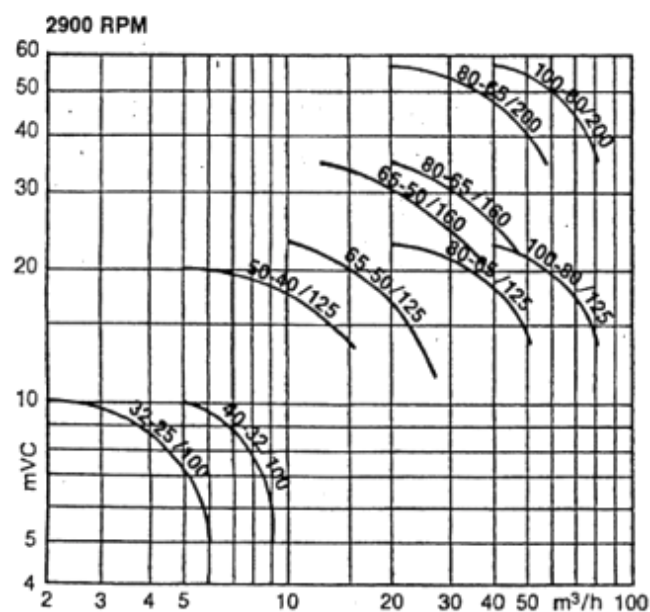

All dimensions in millimeters

For detailed performance refer to individual performance curve

# Type RS - BARE SHAFT PUMP.

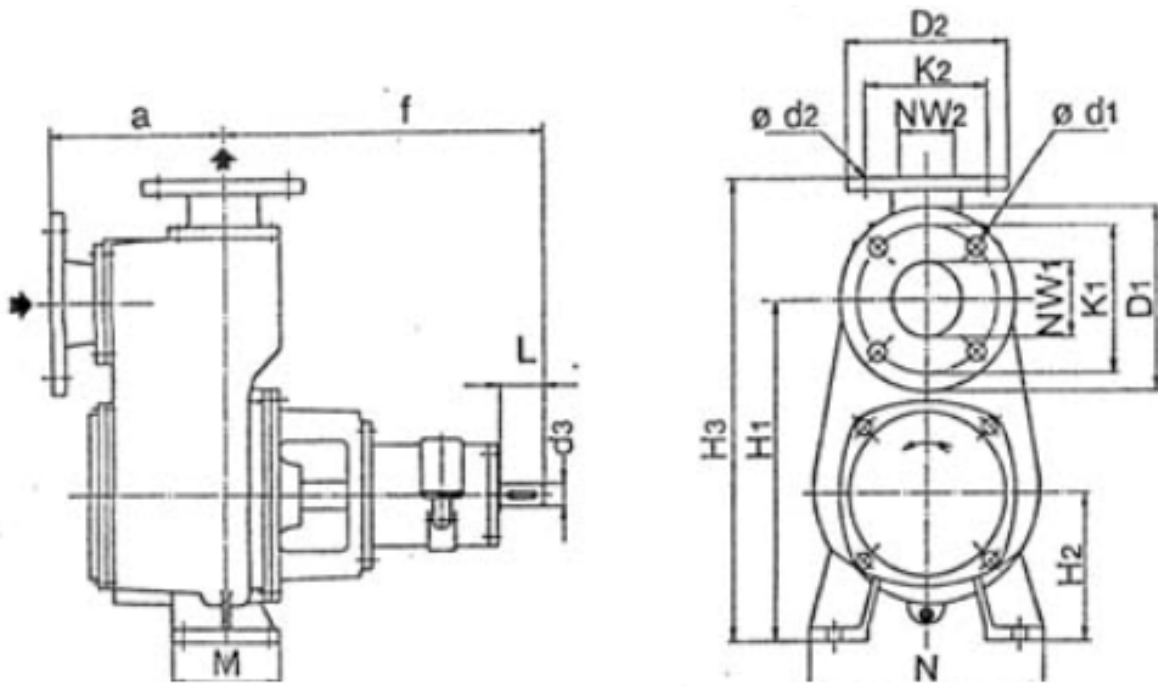

ALL OTHER INFORMATION, SEE BULLETIN 781005 FOR CLOSE COUPLED PUMP TYPE RSM.

TYPE	SUC. FLANGE				DEL. FLANGE				ALL DIMENSIONS IN MILLIMETERS								PUMP WEIGHT KG	SHAFT END	
	NW1	K1	D1	d1	NW2	K2	D2	d2	a	f	H1	H2	H3	M	N	I		d3	
32-25/100	32	100	140	4-18	25	85	115	4-14	145	360	240	90	340	100	180	30	50	24	
40-32/100	40	110	150	4-18	32	100	140	4-18	145	360	240	90	340	100	180	35	50	24	
50-40/125	50	125	165	4-18	40	110	150	4-18	160	360	280	112	405	100	210	45	50	24	
65-50/125	65	145	185	4-18	50	125	165	4-18	160	360	280	112	405	100	210	47	50	24	
80-65/125	80	160	200	8-18	65	145	185	4-18	210	360	327	132	475	125	240	70	50	24	
100-80/125	100	180	220	8-18	80	160	200	8-18	210	360	327	132	475	125	240	75	50	24	
65-50/160	65	145	185	4-18	50	125	165	4-18	200	360	370	160	505	125	265	70	50	24	
80-65/160	80	160	200	8-18	65	145	185	4-18	200	360	370	160	505	125	265	75	50	24	
80-65/200	80	160	200	8-18	65	145	185	4-18	210	470	420	180	570	160	345	95	80	32	
100-80/200	100	180	220	8-18	80	160	200	8-18	210	470	420	180	570	160	345	100	80	32	
80-65/250	80	160	200	8-18	65	145	185	4-18	210	470	465	200	615	160	400	115	80	32	
100-80/250	100	180	220	8-18	80	160	200	8-18	210	470	465	200	615	160	400	120	80	32	

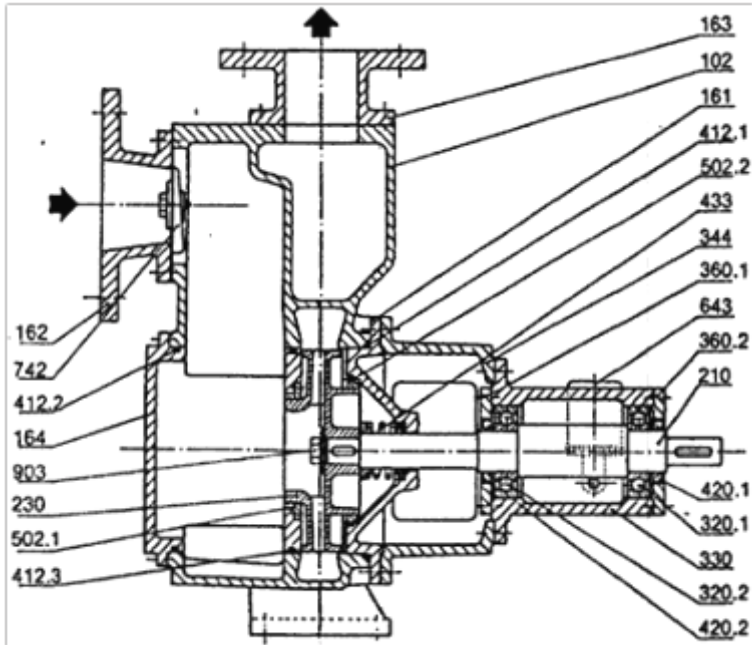

pos no.	Description	pcs.	Material
102	Volute casing	1	c.l./brz.
161	Casing cover	1	c.l./brz.
162	Suction cover	1	c.l./brz.
163	Discharge cover	1	c.l./brz.
164	Inspection cover	1	c.l./brz.
210	Pump shaft	1	st. stl.
230	Impeller	1	brz.
320.1	Radial ball bearing	1	
320.2	Radial ball bearing	1	
330	Bearing housing	1	c.l
344	Bearing bracket lantern	1	c.l
360.1	Bearing cover	1	c.l
360.2	Bearing housing	1	c.l
412.1	O-ring	1	
412.2	O-ring	1	
412.3	O-ring	1	
420.1	Shaft seal ring	1	
420.2	Shaft seal ring	1	
433	Mech. seal	1	
502.1	Casing wear ring	1	brz.
502.1	Casing wear ring	1	brz.
643	Oil level sight glass	1	
742	Check valve	1	Nitril rubber
903	Washer a. set screw-imp	1	st. stl.

1450 rpm - 2900 rpm

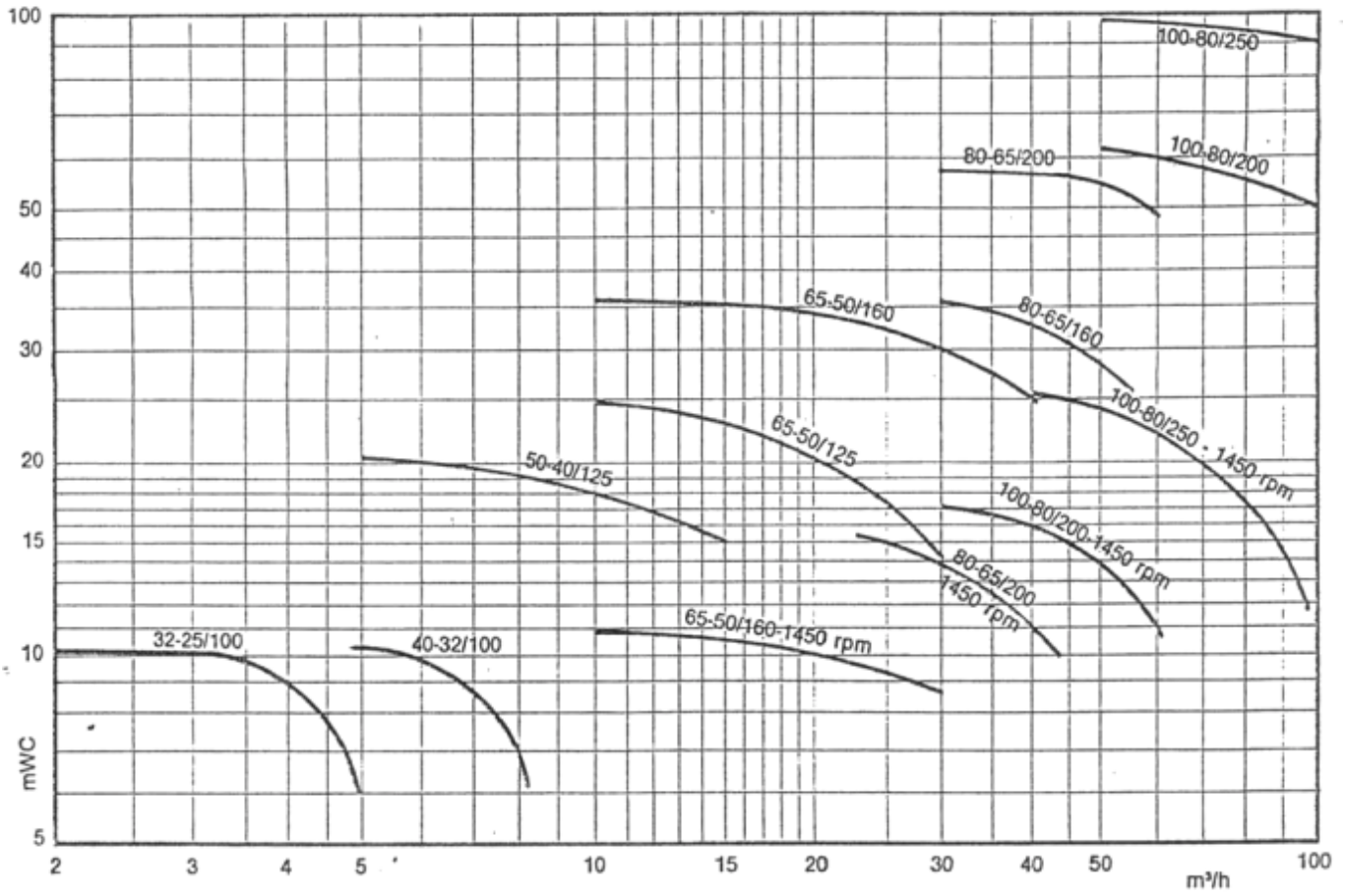

1750 rpm - 3500 rpm

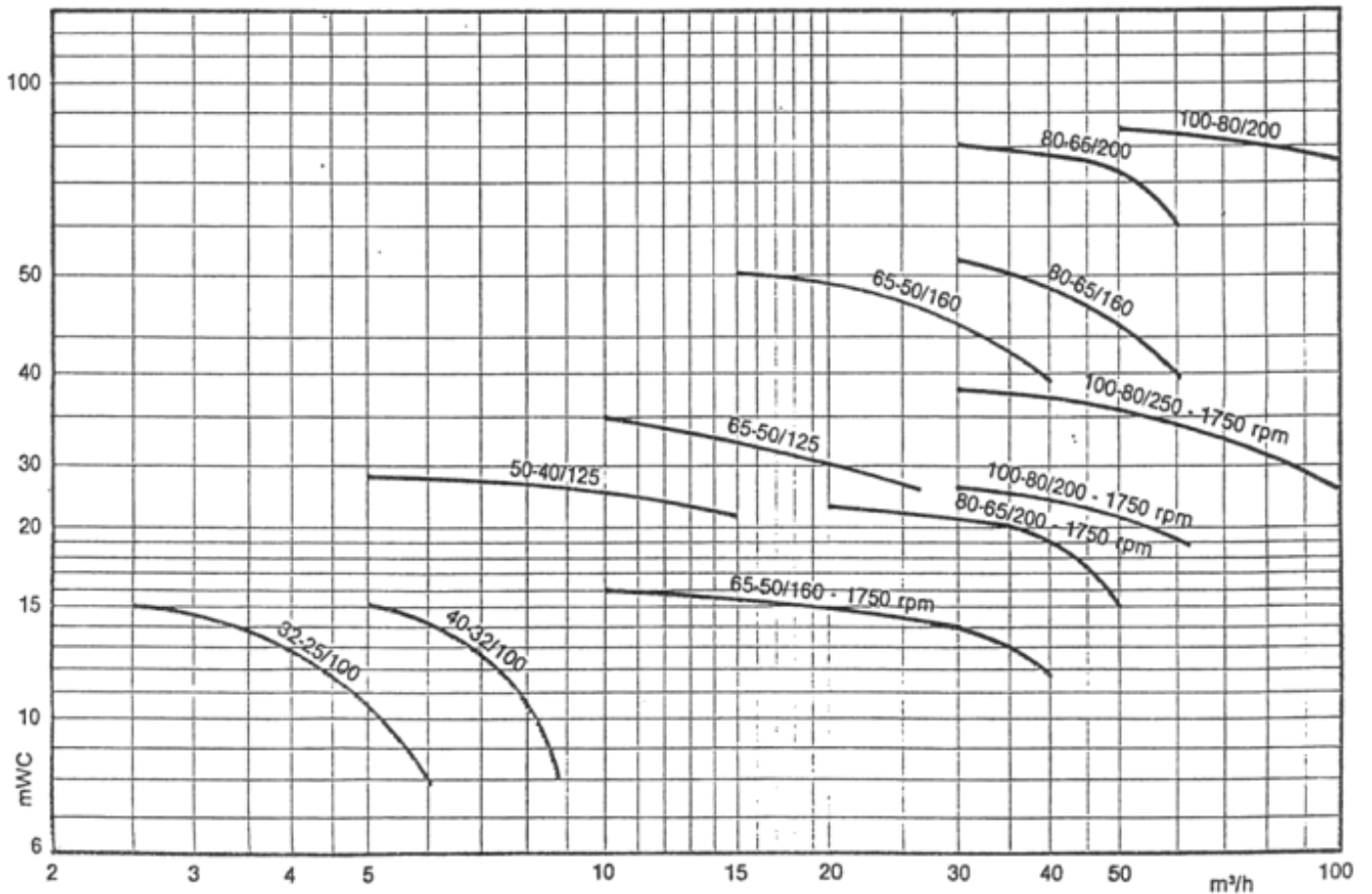

FOR DETAILED PERFORMANCE REFER TO INDIVIDUAL PERFORMANCE CURVE

# SPECIFICATIONS

## CASING

Volute casing in one piece and designed for back pull-out of motor support and rotating element without disturbing the suction and discharge piping. Suction and discharge covers are bolted to pump casing. Foundation cast integral with casing. Casing provided with filling plug, vent connections, gauges connections and draining.

## IMPELLER

Enclosed, single suction type designed for best efficiency and low NPSH. Cast in one piece - exterior surfaces machined, interior surfaces are hand finished. Accurately dynamical balanced to minimize thrust and insure longer life and smooth operation. Impeller is keyed to the shaft and locked in position by lock washer.

## SHAFT

Double volutes in pump casing and usually short span keeps deflection and vibration to a minimum. Made of heat-treated stainless steel - turned and ground to exact dimensions. Locked to the motorshaft by lock screws.

## STUFFING BOX

As standard a mechanical seal of single type II is provided in the stuffing box. All parts in stainless steel, stationary seat ring ceramics, rotating seat ring in carbon, and the below in synthetic rubber. Other combinations upon request.

## PACKING

An O-ring provides tightness between covers and pump casing, thus the trouble with loose packings and packing material has been eliminated.

## BASE

In standard construction a normal for B 5-motor is used. Pumps can be fitted with steel base - then motor must be in form B5/B3.

## FLANGES

All flanges are made to DIN 2502 TN 10 or ISO 2858 - Can be made to ASA or other standards.

## NAMEPLATE

All pumps will have a nameplate with fabrication number and pump data - Pump casing will be stamped with hydraulic test and pump Number.

IRON Pump A/S  
Generatorvej 10  
DK-2730 Herlev

Phone: +45 44916788  
Fax: +45 44911644

Web: [www.ironpump.dk](http://www.ironpump.dk)  
e-mail: [salg@ironpump.dk](mailto:salg@ironpump.dk)

